

User Guide

- We recommend using CHAMDRILL in rotating or stationary applications with a maximum of .0008" outer cutting points or chisel runout for optimum performance. Larger runout will influence drill performance and hole quality.
- In case of stationary applications we recommend clamping the drill in an orientation which directs both outer cutting points parallel to machine "X" axis.
- On stationary (lathe) applications, if there are misalignment problems it is recommended to use alignment devices such as the ISCAR/ETM GYRO device. Misalignment will cause poor performance of the CHAMDRILL or even tool breakage!

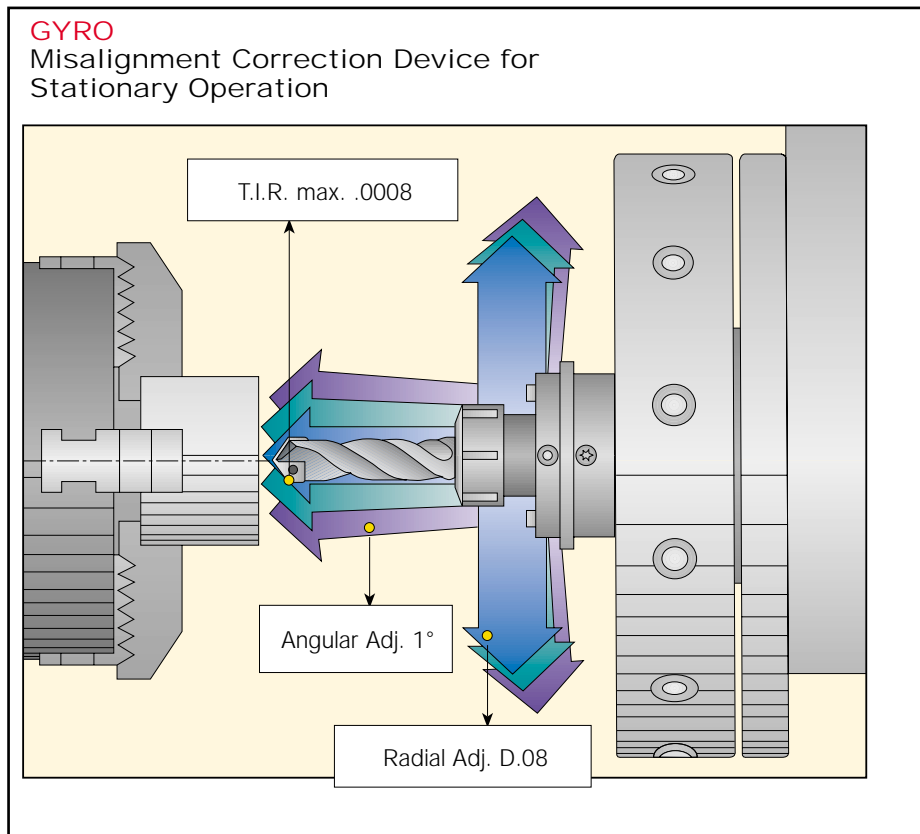

- If chip formation or chip evacuation problems are encountered, follow these recommendations:
 1. Reduce cutting speed by 10%
 2. Increase internal coolant pressure
 3. Apply a pecking cycle
- Use of internal and external coolant during drilling is recommended for achieving prolonged edge life. When only external coolant can be applied it is recommended to drill into a maximum depth of 2X the drill diameter.
- Semi-synthetic or emulsion lubricants are recommended in order to extend tool life.
- Dry machining should not be performed under any circumstances.
- The new CHAMDRILLS can be clamped in ISCAR tooling systems such as:
 1. Collet chucks
 2. Side lock adapters
 3. Power/hydraulic chucks

- We recommend:
 - JET 2 collet chucks for internal and external coolant jets.
 - Using CHAMDRILL in SHORTIN adaptation with collets, for achieving higher tool life and improved performance.
 - Drilling sloped surfaces of a maximum 6°. Reduce feed by 30-50% when penetrating a sloped surface. Recommended exit surface angle is a maximum of 30°. In that case feed should be reduced by 30-50%. Sloped surfaces of more than 6° require spot or pre-hole centering to avoid drill deviation or poor drill performance.
- Both options of stacked plate drilling are possible – with and without gap. (A minimum gap of .08" between plates is recommended).
- Interrupted cut has direct influence on hole accuracy, quality and drill tool life.
- CHAMDRILL can not be used on FITBORE or any other radial adjustment adaptation device.
- Before clamping a new drilling head, apply some oil in the CHAMDRILL pocket. This practice reduces pocket wear and increases the number of indexing cycles.
- Attached is a sketch which may help in identifying the indications of a worn-out drill head (see page 11).
- A general troubleshooting guide is attached, for suggesting solutions to the most common problems. (See pages 14-15).

CHAMDRILL

DCM Indexable Head Drills Drilling Depth **3xD**

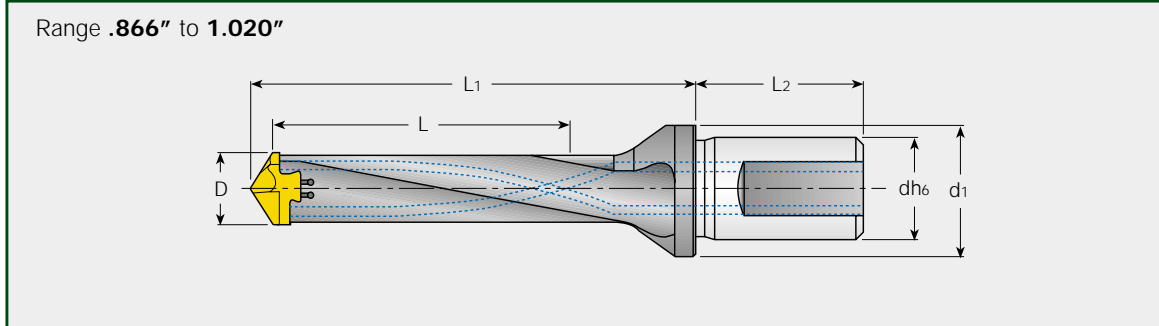

DCM

$\phi D^{(*)}$ Range	L	Designation	d	d ₁	L ₁	L ₂	Pocket Size	Key
.866-.901	2.60	DCM 0866-260-100A-3D	1.00	1.26	3.74	2.20	22	K DCM-22
.906-.941	2.71	DCM 0906-272-100A-3D	1.00	1.26	3.92	2.20	23	K DCM-23
.945-.980	2.83	DCM 0945-283-100A-3D	1.00	1.26	4.08	2.20	24	K DCM-24
.984-1.020	2.95	DCM 0984-295-100A-3D	1.00	1.26	4.29	2.20	25	K DCM-25

Hole tolerance: D+0.02 in average conditions, however, it can be higher or lower according to machine and tooling conditions.

CHAMDRILL

DCM Indexable Head Drills Drilling Depth **5xD**

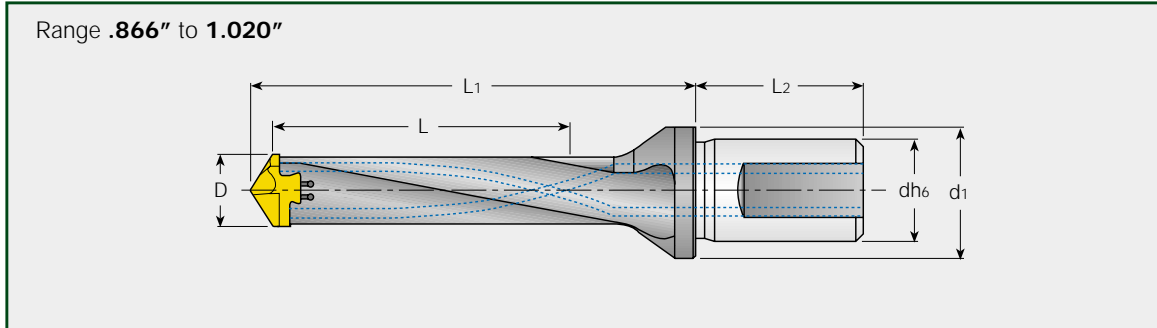

DCM

øD Range	L	Designation	d	d ₁	L ₁	L ₂	Pocket Size	Key	Drilling Heads
.866-.901	4.33	DCM 0866-433-100A-5D	1.000	1.26	5.47	2.20	22	K DCM-22	IDI
.906-.941	4.53	DCM 0906-453-100A-5D	1.000	1.26	5.72	2.20	23	K DCM-23	
.945-.980	4.72	DCM 0945-472-100A-5D	1.000	1.26	5.97	2.20	24	K DCM-24	
.984-1.020	4.92	DCM 0984-492-100A-5D	1.000	1.26	6.26	2.20	25	K DCM-25	

(1) Do not mount smaller drilling heads than specified range for drill body.

Hole tolerance: D+0.02 in average conditions, however, it can be higher or lower according to machine and tooling conditions.

Drilling Heads for DCM Drills

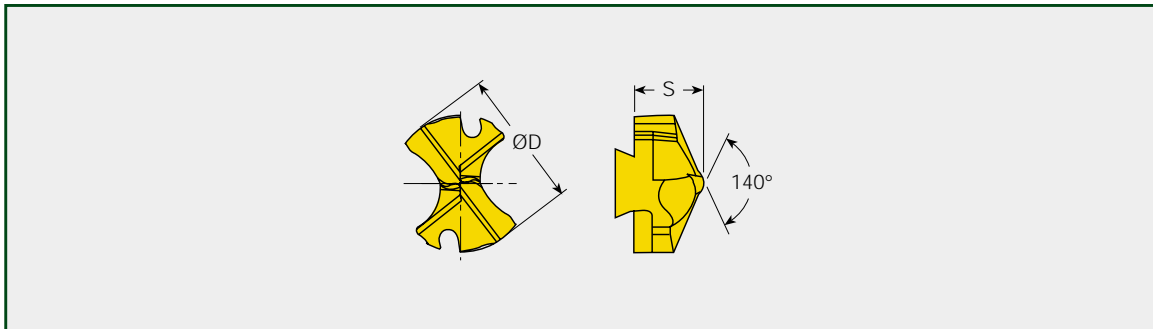

IDI

Designation	D Range (1)		Pocket Size	IC908
	s			
IDI : : -SG IDI : : -SK(2)	.866-.901	.366	22.0	●
	.906-.941	.385	23.0	●
	.945-.980	.393	24.0	●
	.984-1.02	.417	25.0	●

(1) Heads are available in increments of .004.

(2) SK heads for drilling cast iron available in IC 908.
Ordering examples for .524 drill head: IDI 133-SG IC528.

ISO P ISO M ISO K

CHAMDRILL USER GUIDE

Coolant

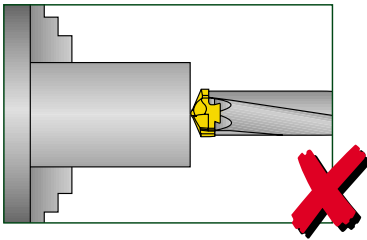
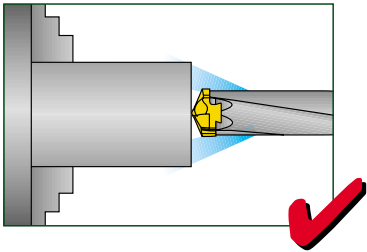
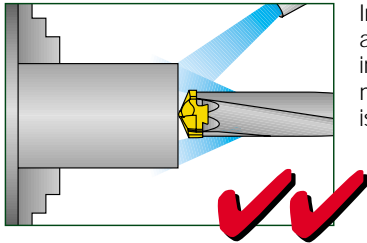

Drilling Head Mounting Procedure

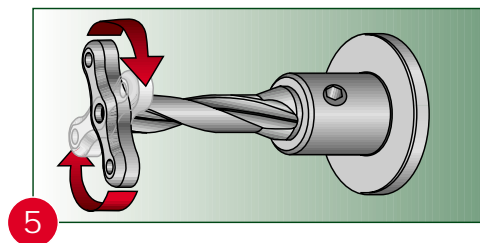
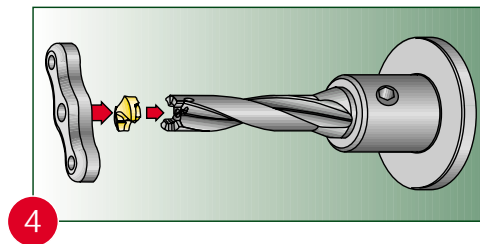
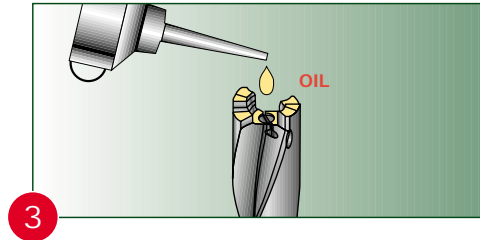
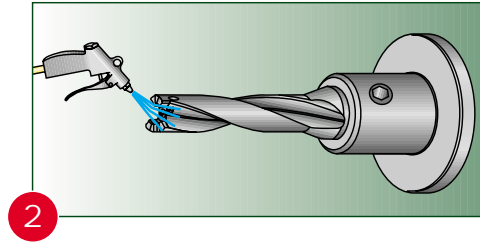
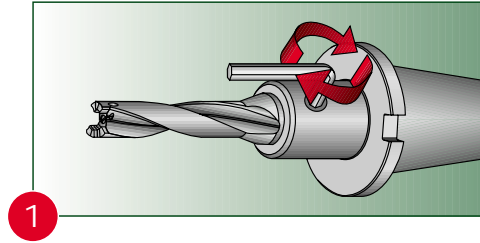

CHAMDRILL USER GUIDE

Power/Force Requirements

Drilling Limitations

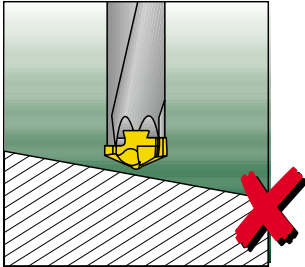

Drilling can be done on 6° maximum angular surface .

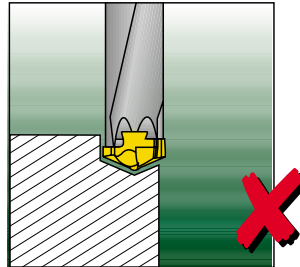

Regrinding of drill head is not recommended; it may cause drill malfunction.

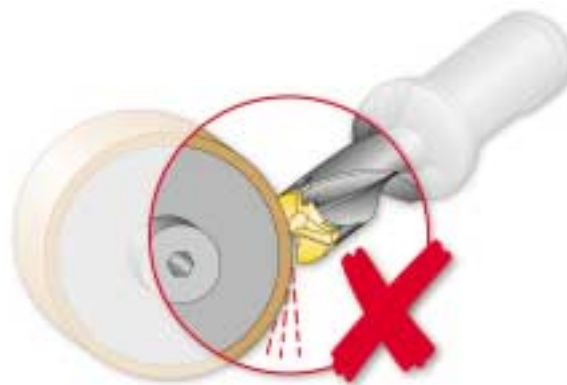

Power/Force Requirements

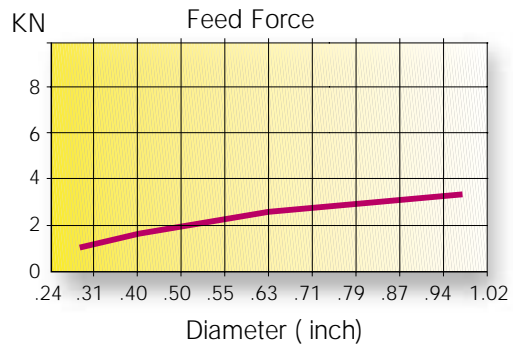
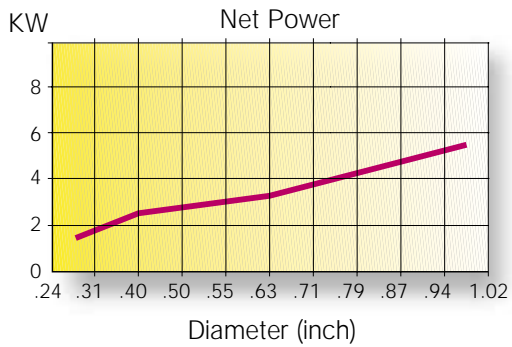

Material: SAE 4340

Speed: 330 sfm

Feed: .008 ipr

Values change for different materials and drilling conditions.

CHAMDRILL USER GUIDE

Indications of Drilling Head Wearing Out

1 Wear Limit

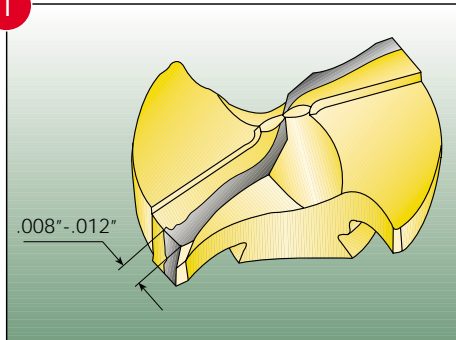

2 Power Restriction

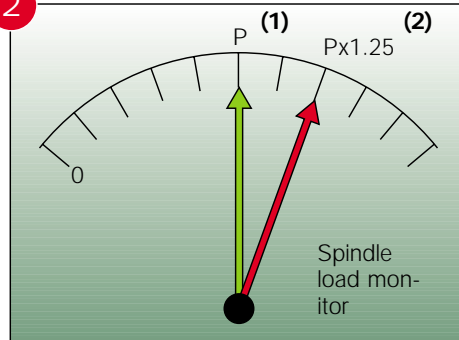

(1) New drilling head
(2) Worn out drilling head

3 Diameter Change

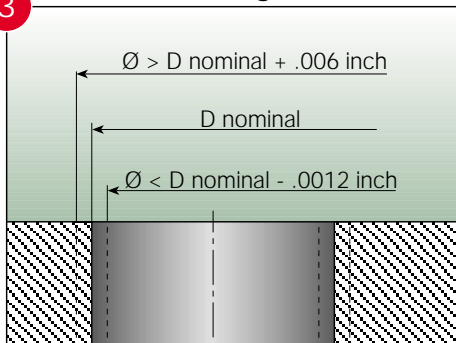

4 Surface Finish Declines

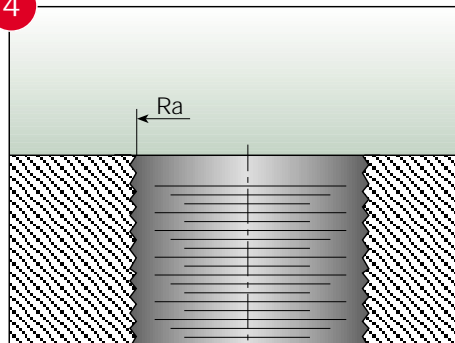

5 Noise of Vibration Drastically Increases

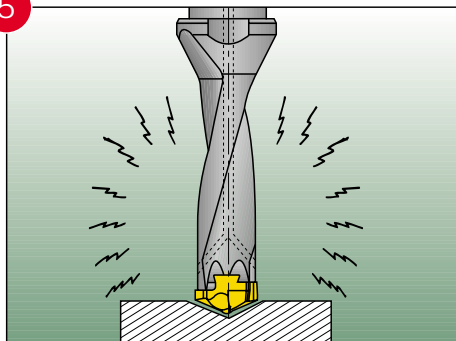

CHAMDRILL Unlocking Change in Torque

Typical Unlocking Torque Range

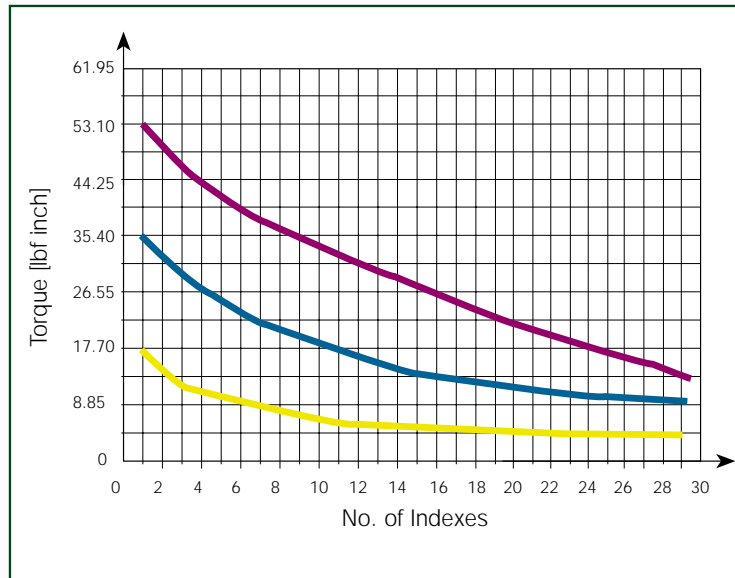

Dia. .669-1.020
 Dia. .433-.630
 Dia. .295-.413

The number of indexing changes according to machine/clamping rigidity machining conditions, workpiece material, coolant, cooling pressure and correct usage.

Torque Inspection Key

Torque keys are available for checking minimal clamping torque. If a "click" is not heard while unclamping with the torque key, the drill must be replaced.

- TK DCM-8
- TK DCM-9
- TK DCM-10
- TK DCM-11
- TK DCM-12
- TK DCM-13
- TK DCM-14
- TK DCM-15
- TK DCM-16
- TK DCM-17
- TK DCM-18
- TK DCM-19
- TK DCM-20
- TK DCM-21
- TK DCM-22
- TK DCM-23
- TK DCM-24
- TK DCM-25



Machining Conditions

Internal Coolant Pressure Recommended Cooling Pressure and Flow Rate

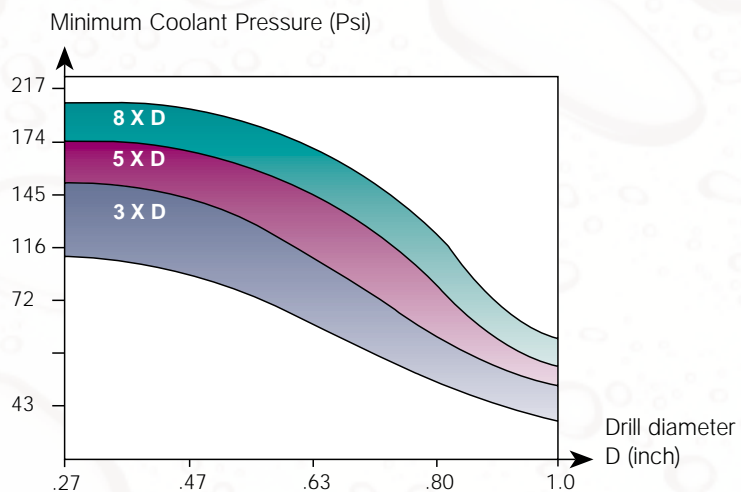
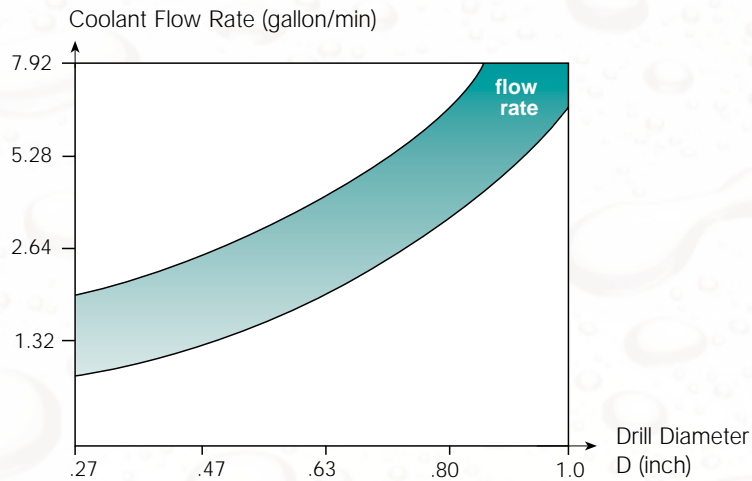

* For special drills more than 8xD, it is recommended to use higher coolant pressure: 217-1015 Psi.

To guarantee chip evacuation, the coolant must always flow through the tool. If the machine is not equipped with coolant through the spindle, we recommend using a coolant inducer. External coolant supply can be used if hole depth is less than 1xD and reduced cutting data is applied. The diagram shows the coolant flow rates for different drills and pressures.

Coolant Mix

Recommended emulsion mix is 6%-8%.
When drilling in stainless and high strength steels a mix of 10% is recommended.

Dry Drilling

It is possible to drill without coolant in cast iron and steel. Oil mist through the drill is then required (for 2xD max).

CHAMDRILL USER GUIDE

Troubleshooting

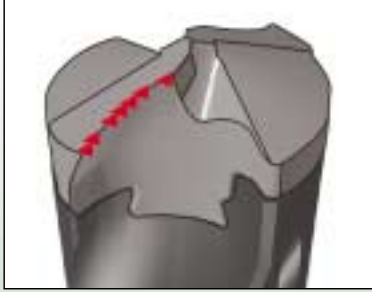

Cutting Edge Chipping

1. Check the stability of the machine spindle, tool and workpiece clamping rigidity.
2. Reduce feed rate, increase speed.
3. If the drill vibrates, reduce cutting speed and increase feed rate.
4. When drilling rough, hard or sloped surface (up to 6°), reduce the feed rate by 30%-50% during entrance and exit.
5. Check cooling lubricant. Increase coolant pressure. In case of external coolant supply, improve jet direction and add cooling jets.



Chisel Area Chipping

1. Reduce feed rate.
2. Increase coolant pressure.
3. Check the adaptation. Use hydraulic clamping chuck, MAXIN power chuck or side lock systems.
4. Increase workpiece chucking force.



Excessive Flank Wear

1. Check that the correct geometry is used.
2. Reduce cutting speed.
3. Increase internal coolant pressure.



Excessive Flute Land Wear

1. Check that the correct geometry is used.
2. Check the runout and make sure it is within .001 inch T.I.R. (radial and axial).
3. Reduce cutting speed.
4. When drilling rough, hard or sloped surface (up to 6°), reduce the feed rate by 30%-50% during entrance and exit.
5. Increase coolant pressure.
6. Check the chisel point runout and make sure it is within .001 inch T.I.R.
7. Increase workpiece chucking force stability and rigidity.
8. If there is low pocket gripping force - replace drill body.

Troubleshooting

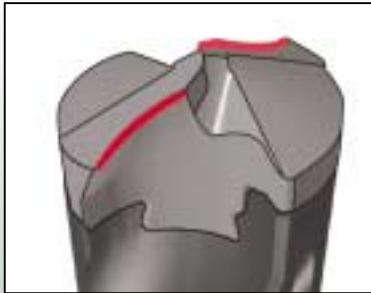

Built-Up Edge

1. Increase cutting speed.
2. Increase coolant pressure.

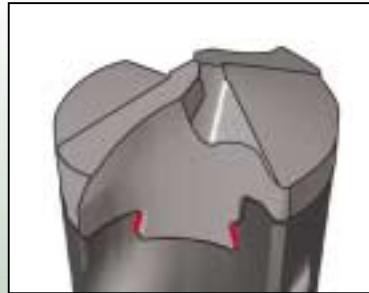

Insufficient Pocket Gripping Torque

1. Check unlocking gripping torque with TK DCM torque key. If there is no click indication - replace drill head.
2. Increase coolant pressure.

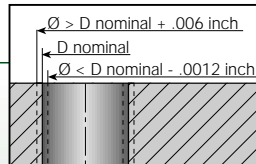

Deviation of Hole Tolerance

1. Check the runout and make sure it is within .001 inch T.I.R. (radial and axial cutting points).
2. Reduce feed rate.
3. Check the chisel point runout and make sure that it is within .001 inch T.I.R.
4. Wrong cutting edge. Replace head.
5. Increase workpiece chucking force.
6. Check the adaptation. Use hydraulic clamping chuck, MAXIN power chuck or side clamping systems.
7. Increase internal coolant pressure.

Inaccurate Hole Position

1. Check the runout and make sure it is within .001 inch T.I.R. (radial and axial).
2. Check the stability of the machine spindle, tool and workpiece clamping rigidity.
3. When drilling rough, hard or sloped surface (up to 6°), reduce the feed rate by 30%-50% during entrance.
4. Drill a pre-hole with a 140° point angle for centering.
5. Check the chisel point runout and make sure it is within .001 inch T.I.R.

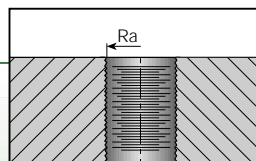

Surface Finish Too Rough

1. Check the runout and make sure it is within .001 inch T.I.R. (radial and axial).
2. Adjust the feed for improved chip formation.
3. In case of chip jamming - increase the coolant flow and/or reduce the cutting speed.
4. Increase the coolant pressure.
5. Check the chisel point runout and make sure it is within .001 inch T.I.R.
6. Use pecking cycle.

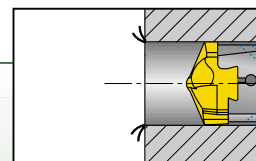

Burrs on Exit

1. Reduce the feed rate by 30%-50% during exit.
2. Replace the worn head.
3. Check the adaptation. Use hydraulic clamping chuck, MAXIN power chuck or side clamping systems.

CHAMDRILL USER GUIDE

Machining Data for DCM

ISO	Material	Condition	Tensile Strength [Kpsi]	Hardness HB	Material No.		
P	Non-alloy steel and cast steel, free cutting steel	< 0.25 %C	Annealed	61	125	1	
		>= 0.25 %C	Annealed	94	190	2	
		< 0.55 %C	Quenched and tempered	123	250	3	
		>= 0.55 %C	Annealed	109	220	4	
			Quenched and tempered	145	300	5	
	Low alloy steel and cast steel (less than 5% of alloying elements)	Annealed		87	200	6	
			Quenched and tempered	135	275	7	
		Quenched and tempered		145	300	8	
				174	350	9	
	High alloyed steel, cast steel, and tool steel	Annealed		99	200	10	
		Quenched and tempered		160	325	11	
M	Stainless steel and cast steel	ferritic/martens.		99	200	12	
		martensitic		119	240	13	
		austenitic		87	180	14	
K	Cast iron nodular (GGG)	Ferritic/pearlitic			180	15	
		Pearlitic			260	16	
	Grey cast iron (GG)	Ferritic			160	17	
		Pearlitic			250	18	
	Malleable cast iron	Ferritic			130	19	
		Pearlitic			230	20	
N	Aluminum-wrought alloy	Not cureable			60	21	
		Cured			100	22	
	Aluminum-cast, alloyed	<=12% Si	Not cureable			75	23
			Cured			90	24
		>12% Si	High temperature			130	25
	Copper alloys	>1% Pb	Free cutting			110	26
			Brass			90	27
			Electrolitic copper			100	28
	Non metallic		Duroplastics, fiber plastics				29
			Hard rubber				30
S	High temp. alloys	Fe based	Annealed			200	31
			Cured			280	32
	Super alloys	Ni or Co based	Annealed			250	33
			Cured			350	34
			Cast			320	35
	Titanium Ti alloys				58		36
			Alpha+beta alloys cured		152		37
H	Hardened steel	Hardened			55 HRC	38	
		Hardened			60 HRC	39	
	Chilled cast iron	Cast			400	40	
	Cast iron	Hardened			55 HRC	41	

Chipformer should be selected based on our geometry recommendations, (Page K4).
 When using coolant supply only, reduce cutting speed by 10%.
 Use internal coolant supply when machining austenitic stainless steel.

CHAMDRILL USER GUIDE

Cutting Speed Vc sfm	Feed vs. Drill Diameter ipr					
	D=.268-.429	D=.433-.508	D=.512-.587	D=.591-.665	D=.669-.823	D=.827-1.020
160-430	.005-.008	.006-.010	.008-.012	.010-.014	.010-.018	.010-.018
330-390						
300-360						
300-390						
230-300						
260-430	.005-.008	.006-.010	.008-.012	.010-.014	.012-.016	.012-.018
230-360						
200-300						
130-230						
160-260	.005-.008	.005-.009	.006-.010	.008-.011	.010-.013	.010-.014
130-230						
70-160	.003-.006	.005-.009	.005-.006	.006-.008	.006-.009	.006-.011
300-460	.008-.012	.010-.014	.012-.016	.014-.018	.016-.020	.016-.024
260-430						
330-590						
300-520						
300-520	.008-.014	.010-.016	.012-.018	.014-.018	.016-.024	.016-.026
260-390						
300-520						
100-160	.002-.004	.003-.005	.004-.006	.005-.007	.005-.008	.005-.009
70-130						
70-160						
70-160						
70-160	.002-.005	.004-.006	.005-.007	.006-.008	.006-.009	.006-.010
70-160	.002-.005	.004-.006	.005-.007	.006-.008	.006-.009	.006-.010